

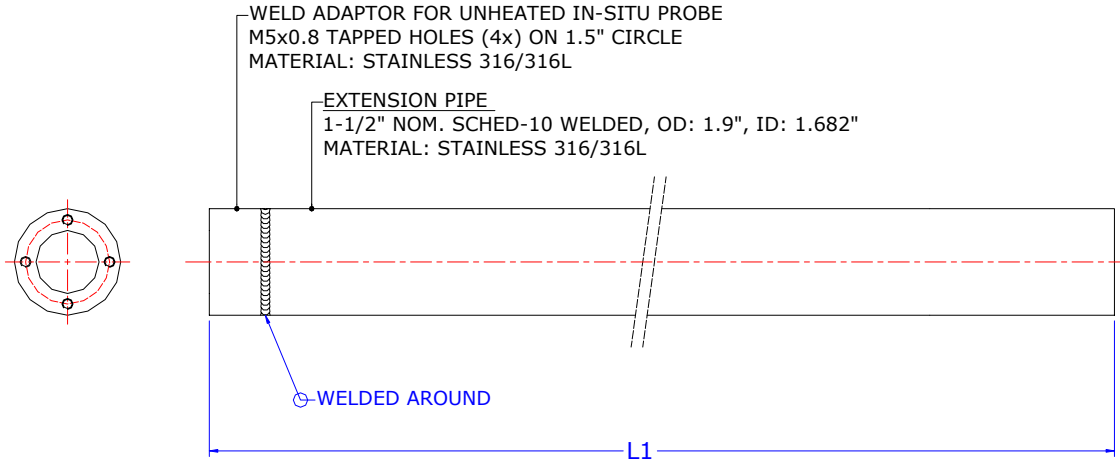

IN-SITU DILUTING SAMPLER EXTENSION PIPE
 BASIC ASSEMBLY NUMBER: XP-1.5S10-SS-NMF

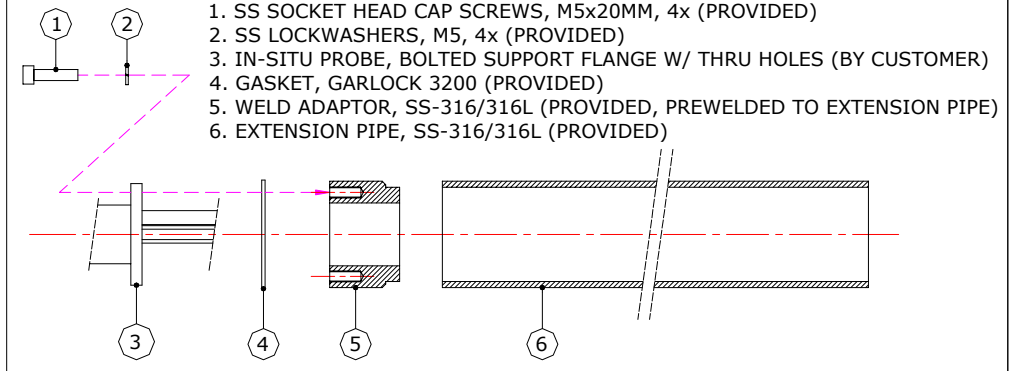

WELD ADAPTOR FOR UNHEATED IN-SITU PROBE
 M5x0.8 TAPPED HOLES (4x) ON 1.5" CIRCLE
 MATERIAL: STAINLESS 316/316L

EXTENSION PIPE
 1-1/2" NOM. SCHED-10 WELDED, OD: 1.9", ID: 1.682"
 MATERIAL: STAINLESS 316/316L

ENG. NOTES:

1. WELD ADAPTOR: MAT. STAINLESS 316/316L
2. EXTENSION PIPE: MAT. STAINLESS 316/316L
3. EXTENSION PIPE: 1-1/2" NOM. SCHED-10 WLD PIPE, SPECIFY IF OTHER
4. EXTENSION PIPE: "L1" SPECIFY THIS LENGTH FROM END TO END
5. MOUNTING FLANGE: N/A
6. PROBE EXTENSION TUBES: REF DWG: XP-TUBESET-01_V01A_QXXX-XXXX08
- 7.
- 8.

CUSTOMER NOTES/CHANGES:
