



**RETROFITTING THE EPM IN-SITU PROBE HEATERS TO THE COMPACT ASI MODEL**

**Overview:** This paper describes in some detail, the differences between the formerly available EPM in-situ dilution probe heaters, and the new ASI heaters. The details herein should be considered when retrofitting the discontinued EPM model 797.502/.502E, or the obsolete model 797.560 series in-situ dilution probe heaters, to the more compact ASI model DP-060 series in-situ dilution probe heaters.

**Dilution Probe Filter Cap Assemblies:**

It is critical that the filter cap assembly located at the front of the dilution probe is the correct type for the heater assembly that you are or will be using, as they are designed to provide the proper gas tight seal between the front of the probe and probe heater.

Heater models 797.502 and 797.502E (discontinued December 31<sup>st</sup>. 1995) accepted EPM in-situ dilution probe models 797.302 and 797.303 which were fitted with a stainless steel front filter cap assembly that has a beveled edge (P/N: 0041.051). This is an older type of filter cap assembly. In this assembly, the coarse filter gauze of Incoloy® 800 (P/N: 0040.267) is retained by a circlip (P/N: 6132.222).

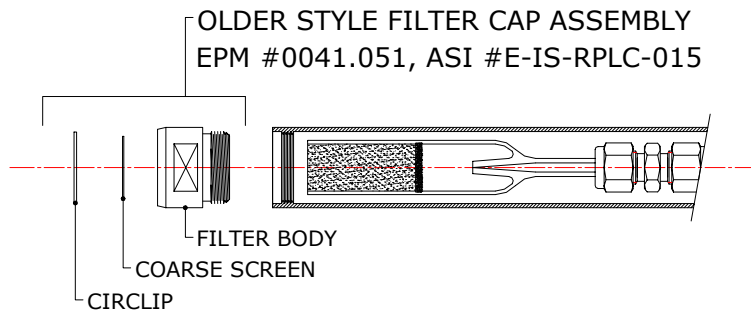

The EPM probe heater models 797.560 and 797.561 (and 797.563) were the last modular heater assemblies designed by EPM. They accepted probe models 797.302 and 797.303, and were sold for new installations and as retrofit to the discontinued EPM model 797.502 series heaters (with modifications required to the probe and to the extension pipe). The filter cap assemblies for use with later design heater/probe configuration had a Hastelloy® C276 coarse filter gauze (P/N: 0042.206), which is mounted between a front cap and filter union. The front cap and filter union are screwed together to retain the coarse filter gauze. The front cap, as well as the filter union are made of Inconel® 600 or Hastelloy® C22. Specific configurations are noted on the next page.

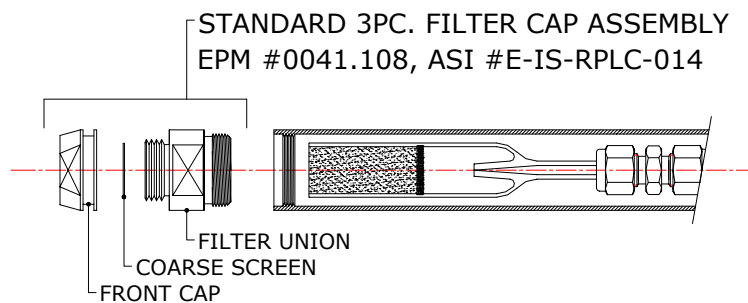

(continued)



- Filter cap assembly for the regular model 797.302/.303 probes (Inconel® 600 or SS-316L)  
When installed in the EPM 797.502/.502E heaters used EPM filter cap assembly P/N: 0041.051  
**(still available through ASI, P/N: E-IS-RPLC-015).**

This filter cap assembly consists of:    6132.222 circlip (SS-316L)  
    0040.267 coarse filter gauze (Incoloy® 800)  
    0041.051 filter body (SS-316) \*complete assembly

- Filter cap assembly for the regular model 797.302/.303 probes (Inconel® 600 or SS-316L)  
When installed in the EPM 797.560L/.561L/.563L heaters used EPM filter cap assembly P/N:  
0041.108  
**(still available through ASI, P/N: E-IS-RPLC-014).**

This filter cap assembly consists of:    0041.110 cap (Inconel® 600)  
    0042.206 coarse filter gauze (Hastelloy® C276)  
    0041.111 filter union (Inconel® 600)

- Filter cap assembly for the regular model 797.302/.303 probes (Inconel® 600 or SS-316L)  
When installed in the EPM 797.560H/.561H/.563H heaters used EPM filter cap assembly P/N:  
0041.210.

This filter cap assembly consists of:    0042.204 cap (Hastelloy® C22)  
    0042.206 coarse filter gauze (Hastelloy® C276)  
    0041.111 filter union (Inconel® 600)

- Filter cap assembly for the Hastelloy® probe model 797.302/.303 probes  
When installed in any of the new modular heaters used EPM filter cap assembly P/N: 0041.208.

This filter cap assembly consists of:    0042.204 cap (Hastelloy® C22)  
    0042.206 coarse filter gauze (Hastelloy® C276)  
    0041.203 filter union (Hastelloy® C22)

### Special Notes:

- Front cap P/N: 0041.110 (Inconel® 600) and front cap P/N: 0042.204 (Hastelloy® C22) are interchangeable.
- Filter union P/N: 0041.111 (Inconel® 600) and filter union P/N: 0041.203 (Hastelloy® C22) are not interchangeable.
- When upgrading the heater for an existing probe, make sure to use the appropriate filter cap assembly.
- All new probes ordered as spare units, or for new installations, will be fitted with the latest style filter cap assembly unless otherwise specified by customer.

(continued)



**Heated Probe Assembly Mounting:**

As the overall length of the heated probe assembly (sample inlet of probe to the face of the heaters mounting flange) is roughly 325 mm (12.8 inches), an "extension-set" is typically needed to extend the assembly further into the stack or process to a point where a representative sample can be drawn (extension lengths specified by customer). The typical extension-set consists of the following:

- An extension pipe: Supports the heated probe assembly, contains the armored heater cable and probe-line extension tubes, determines the distance of the sample inlet into the stack or process.
- A mounting flange: Welded to the back of the extension pipe, secures the entire extension pipe with heated probe at the customers stack port.
- An extension ring (counter flange): Welded to the front of the extension pipe, joins the heated probe to the extension pipe.
- Probe-line extension tubes: Extends the standard probe-lines through the extension pipe and out to the umbilical cord, ((4) four ea. Per set).

Due to the differences in the design of the model 797.502E and model 797.561 heaters, the *extension ring* was not interchangeable, and they required a different pipe size for the *extension pipe*. The original basic specifications and requirements are noted below.

- |  |  |   |
|--|--|---|
| 1a. <b>EPM Model 797.502</b> in-situ dilution probe heater assembly:                                       |  |   |
| <u>Extension ring</u><br>not included  | <u>Extension pipe</u><br>not specified                         | <u>Stack port size</u><br>not specified   |
| 1b. <b>EPM Model 797.502E</b> in-situ dilution probe heater assembly:                                      |  |   |
| <u>Extension ring</u><br>3-1/2" I.D. SOCKET/WELD<br>(4" O.D. extension ring)                               | <u>Extension pipe</u><br>3" NOM. (3-1/2"O.D.)                  | <u>Stack port size</u><br>minimum ID 4.5" |
| 2a. <b>EPM Model 797.560</b> in-situ dilution probe heater assembly:                                       |  |   |
| <u>Extension ring</u><br>not included  | <u>Extension pipe</u><br>not specified                         | <u>Stack port size</u><br>not specified   |
| 2b. <b>EPM Model 797.561</b> in-situ dilution probe heater assembly:                                       |  |   |
| <u>Extension ring</u><br>4" I.D. SLIP-ON/WELD<br>(5" O.D. extension ring)                                  | <u>Extension pipe</u><br>3-1/2" NOM. (4"O.D.)                  | <u>Stack port size</u><br>minimum ID 5.5" |
| 4a. <b>ASI (Alpha Suite, Inc.) Model DP-060</b> Series in-situ dilution probe heater assembly:             |  |   |
| <u>Extension ring</u><br>END-DISC/SHOULDER WELD3"<br>(3.5" O.D.)   | <u>Extension pipe</u><br>NOM. (3.5"O.D.)<br>(Schedule 10 only) | <u>Stack port size</u><br>minimum ID 4"   |
| 4b. <b>ASI Model DP-060</b> Series in-situ dilution probe heater assembly, for specific special retrofits: |  |   |
| <u>Extension ring</u><br>Customer Specified  | <u>Extension pipe</u><br>Customer Specified                    | <u>Stack port size</u><br>TBD             |



### Special Notes:

- The minimum "Stack port size" noted above does not take into account any build-up of particulate in port or on the heater flange and extension pipe assembly, or the OD of external welds on the assembly by customer.
- The 797.502 did not include heater flange or extension ring. The outside diameter of the heater mantle where a custom adaptor (by customer) can be welded is 2-15/16".
- The 797.560 did not include heater flange or extension ring. The outside diameter of the heater mantle where a custom adaptor (by customer) can be welded is 3-1/2".
- The extension pipe size, and the minimum acceptable stack port size for the 797.502 & 797.560 is determined by the dimensions of the custom adaptor.
- The ASI (Alpha Suite, Inc.) Model DP-060 Series probe heater coils are interchangeable with the old EPM Model 797.560/.561 Series heaters assemblies.

For more information please contact Alpha Suite, Inc. at the number noted above.

**Dilution Solutions...**



**Expert**

**Probe**

**Maintenance...**

**Alpha Suite, Inc.**